

4
& PLAN 5

The Commonwealth of Massachusetts

No. 7925

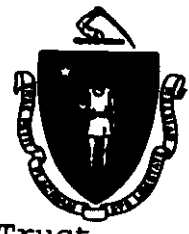

Whereas, Dorothy B. Lunken Trust

of -- Essex --, in the County of -- Essex -- and Commonwealth aforesaid, has applied to the Department of Environmental Protection for license to -- reconstruct and maintain an existing pier, install two 3-pile dolphins, install new timber support posts where necessary and replace deteriorated decking and handrails -----

and has submitted plans of the same; and whereas due notice of said application, ~~and of the time and place fixed for a hearing thereon, has been given,~~ as required by law, to the -- Board of Selectmen -- of the - Town of Essex; -----

NOW, said Department, having heard all parties desiring to be heard, and having fully considered said application, hereby, subject to the approval of the Governor, authorizes and licenses the said

-- Dorothy B. Lunken Trust --, subject to the provisions of the ninety-first chapter of the General Laws, and of all laws which are or may be in force applicable thereto, to -- reconstruct and maintain an existing pier, install two 3-pile dolphins, install new timber support posts where necessary and replace deteriorated decking and handrails ---

in and over the waters of -- Essex River -- in the -- Town -- of -- - Essex - and in accordance with the locations shown and details indicated on the accompanying DEP License Plan No.7925, (4 sheets).

DAVID SMITH
NUCCI VINE ASSOCIATES INC.
253 LOW ST.
NEWBURYPORT, MA 01950

License No. 7925

Page 2

The structures hereby authorized shall be limited to the following uses:
to provide noncommercial docking and boating access to navigable waters.

SPECIAL CONDITIONS

This license will expire thirty (30) years from the date of issuance.

By written request of the licensee for an amendment, the Department may grant a renewal for a term not to exceed that authorized in the original license.

Please see page 3 for additional conditions to this license.-----



Duplicate of said plan, number 7925 is on file in the office of said Department, and original of said plan accompanies this License, and is to be referred to as a part hereof.

STANDARD WATERWAYS LICENSE CONDITIONS

1. Acceptance of this Waterways License shall constitute an agreement by the Licensee to conform with all terms and conditions stated herein.
 2. This License is granted upon the express condition that any and all other applicable authorizations necessitated due to the provisions hereof shall be secured by the Licensee prior to the commencement of any activity or use authorized pursuant to this License.
 3. Any change in use or any substantial structural alteration of any structure or fill authorized herein shall require the issuance by the Department of a new Waterways License in accordance with the provisions and procedures established in Chapter 91 of the Massachusetts General Laws. Any unauthorized substantial change in use or unauthorized substantial structural alteration of any structure or fill authorized herein shall render this Waterways License void.
 4. This Waterways License shall be revocable by the Department for noncompliance with the terms and conditions set forth herein. This license may be revoked after the Department has given written notice of the alleged noncompliance to the Licensee and those persons who have filed a written request for such notice with the Department and afforded them a reasonable opportunity to correct said noncompliance. Failure to correct said noncompliance after the issuance of a written notice by the Department shall render this Waterways License void and the Commonwealth may proceed to remove or cause removal of any structure or fill authorized herein at the expense of the Licensee, its successors and assigns as an unauthorized and unlawful structure and/or fill.
 5. The structures and/or fill authorized herein shall be maintained in good repair and in accordance with the terms and conditions stated herein and the details indicated on the accompanying license plans.
 6. Nothing in this Waterways License shall be construed as authorizing encroachment in, on or over property not owned or controlled by the Licensee, except with the written consent of the owner or owners thereof.
 7. This Waterways License is granted subject to all applicable Federal, State, County, and Municipal laws, ordinances and regulations including but not limited to a valid final Order of Conditions issued pursuant to the Wetlands Protection Act, G.L. Chapter 131, s.40.
 8. This Waterways License is granted upon the express condition that the use of the structures and/or fill authorized hereby shall be in strict conformance with all applicable requirements and authorizations of the DEP, Division of Water Pollution Control.
 9. This License authorizes structure(s) and/or fill on:
 - Private Tidelands. In accordance with the public easement that exists by law on private tidelands, the licensee shall allow the public to use and to pass freely upon the area of the subject property lying between the high and low water marks, for the purposes of fishing, fowling, navigation, and the natural derivatives thereof.
 - Commonwealth Tidelands. The Licensee shall not restrict the public's right to use and to pass freely, for any lawful purpose, upon lands lying seaward of the low water mark. Said lands are held in trust by the Commonwealth for the benefit of the public.
 - a Great Pond of the Commonwealth. The Licensee shall not restrict the public's right to use and to pass freely upon lands lying seaward of the high water mark for any lawful purpose.
- No restriction on the exercise of these public rights shall be imposed unless otherwise expressly provided in this license.
10. Unless otherwise expressly provided by this license, the licensee shall not limit the hours of availability of any areas of the subject property designated for public passage, nor place any gates, fences, or other structures on such areas in a manner that would impede or discourage the free flow of pedestrian movement thereon.

License No. 7925

Page 4

The amount of tidewater displaced by the work hereby authorized has been ascertained by said Department, and compensation thereof has been made by the said -- Dorothy B. Lunken Trust -- by paying into the treasury of the Commonwealth -- four dollars and zero cents (\$4.00) for each cubic yard so displaced, being the amount hereby assessed by said Department. (2cu.yds. = \$4.00)

Nothing in this License shall be so construed as to impair the legal rights of any person. This License shall be void unless the same and the accompanying plan are recorded within 60 days from the date hereof, in the Registry of Deeds for the County of -- Essex -----

IN WITNESS WHEREAS, said Department of Environmental Protection have hereunto set their hands this twenty second day of April in the year nineteen hundred and ninety nine.

Commissioner



Section Chief

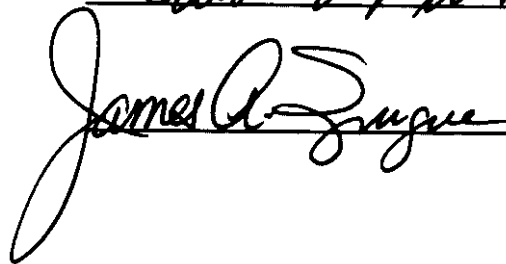

Department of
Environmental
Protection

THE COMMONWEALTH OF MASSACHUSETTS

This license is approved in consideration of the payment into the treasury of the Commonwealth by the said -- Dorothy B. Lunken Trust

the further sum of -- six hundred dollars and zero cents (\$600.00)

the amount determined by the Governor as a just and equitable charge for rights and privileges hereby granted in the land of the Commonwealth.

BOSTON,

Approved by the Governor.



Governor

PLAN BOOK 334/PLAN 22

copy history of plans, 60 unit
sales map,

Received: May 5 1999
with: Bill North
B. Lumber Trust, et al.
rec. 015653P 278

attest: *John B. Vine*
Register of Deeds 4/1/99

I CERTIFY THAT THIS PLAN,
AS PREPARED, CONFORMS TO
THE RULES AND REGULATIONS
OF THE REGISTERS OF DEEDS.



David B. Vine

7/1/99
3

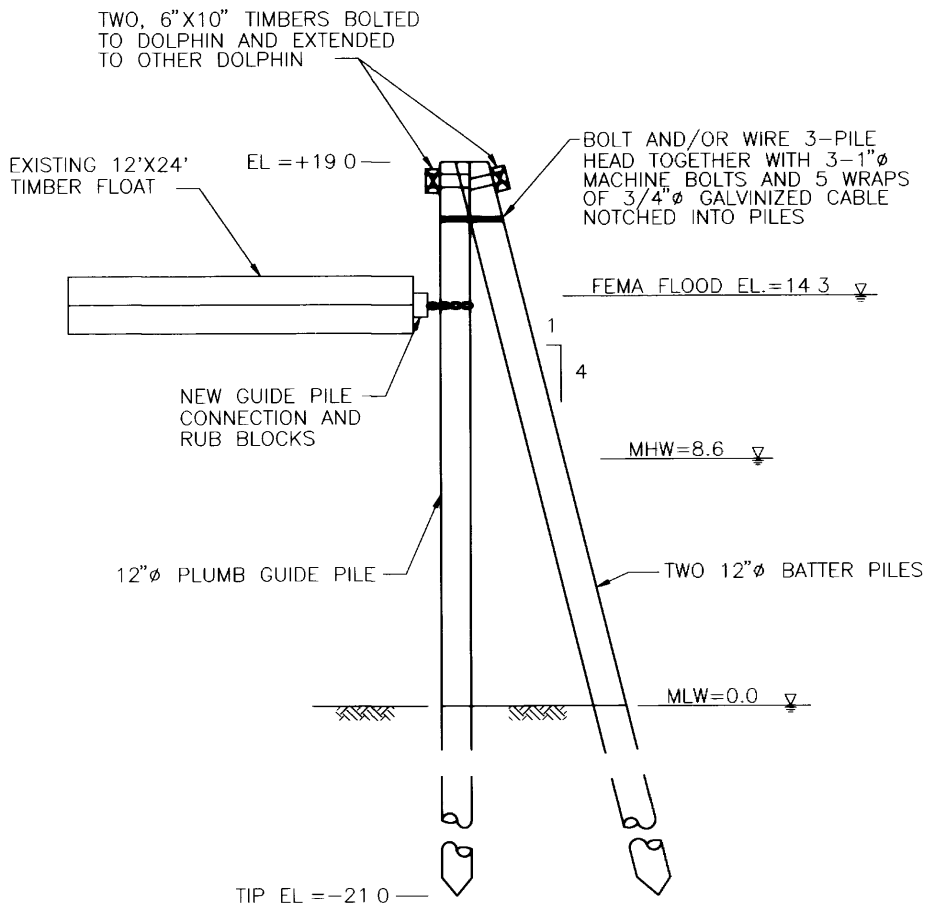

3-PILE DOLPHIN
DETAIL
SCALE 1" = 5'

LICENSE PLAN NO. 7925
Approved by Department of Environmental Protection
Date: APR 22 1999



David B. Vine

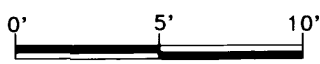

NVA FILE NO 588\DEP

LICENSE PLAN NO. 792.5
Approved by Department of Environmental Protection
Date: **APR 22 1999**

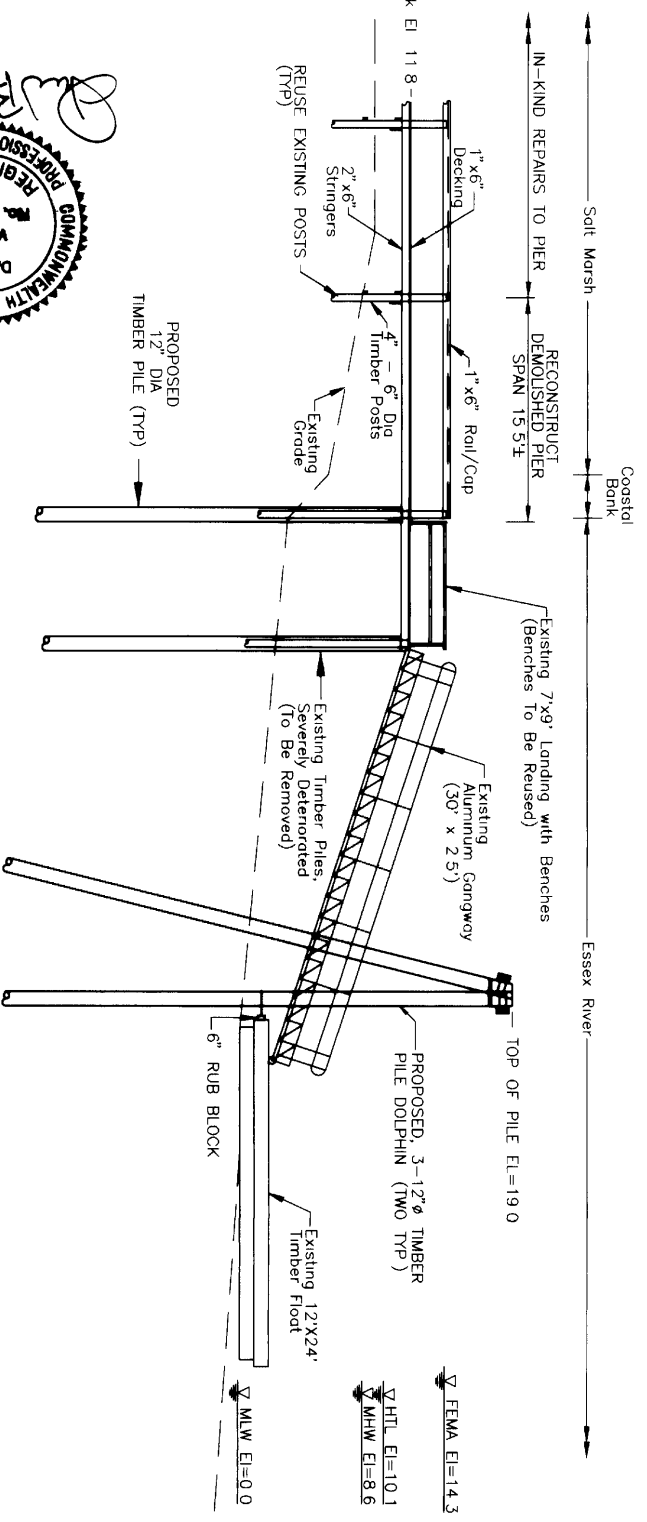

SECTION B-B
SCALE: 1"=10'



Handwritten notes and signatures:
 337-40
 4/22/99
 Region of Coast
 4/22/99

PLAN BOOK 337 PLAN 22
 ESSEX REGISTRY OF DEEDS, SO DIST
 SALEM, MASS.
 Received
 with
 B. Greenblatt
 No. 15689278
 1999

AS PREPARED, CONFORMS TO THE RULES AND REGULATIONS OF THE REGISTERS OF DEEDS.
 I CERTIFY THAT THIS PLAN,
 DAVID B. VINE
 REGISTERED PROFESSIONAL ENGINEER
 No. 29301
 COMMONWEALTH OF MASSACHUSETTS

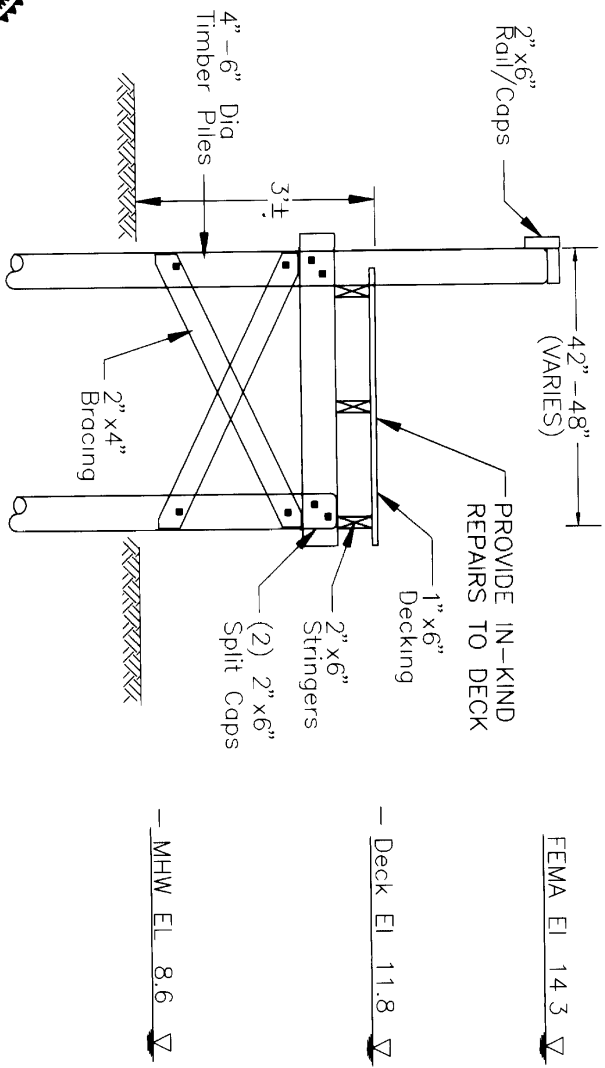

EXISTING TYPICAL SECTION

SCALE: 1"=2'

LICENSE PLAN NO. 7925
Approved by Department of Environmental Protection
Date: APR 22 1999



1216 86m

PLAN BOOK 334 PLAN 29
 every member of D.E.P. shall have
 a copy of this plan
 1999
 Received
 with General Permit # 03
 Number Permit # 298
 No. B15663 P 298
 g. 1800
 Register of Deeds
 4/26



I CERTIFY THAT THIS PLAN,
 AS PREPARED, CONFORMS TO
 THE RULES AND REGULATIONS
 OF THE REGISTERS OF DEEDS.

334 PLAN 29
 4/26